

APEX

APEX SCIENCE & ENGINEERING CORP

(OPTOELECTRONIC DIV.)



新北市中和區新民街 112 號 4 樓 Http : www.apexgroup.com.tw
4F, No. 112, Shin - Min St., Chung Ho Dist, New Taipei City 235, Taiwan, R.O.C.
Tel : 886 - 2 - 2228 - 7331 Fax : 886 - 2 - 2225 - 9169

TBF57003BFL20N

ROHS

DATA SHEET

Acceptance

ISSUE	VERSION	APPROVER	CHECKER	ENGINEER
	A			

Messrs.			
Product Specification	Model:	TBF57003BFL20N	Rev. NO.
			A
			Issued Date.
			Mar,15.21

Contents

1. LCM Specification.....	4
2. Mechanical Specification.....	5
3. Pin Assignment.....	6
4. Electrical Characteristics.....	7
5. Electrical Specification.....	8
6. Optical Specifications.....	10
7. Reliability Test Items.....	12
8. Handling Precautions.....	13
9. Inspection Criterion.....	14
10. Package Specification.....	18

Messrs.				
Product Specification	Model:	TBF57003BFL20N	Rev. NO.	Issued Date.
			A	Mar,15.21

1. LCM Specification

1.1 Description

TBF57003BFL20N is a transmissive type color active matrix liquid crystal display (LCD) which uses amorphous thin film transistor (TFT) as switching devices. This product is composed of a TFT LCD panel, a drive IC, a FPC, and a WLED-backlight unit. The active display area is 7.0 inches diagonally measured and the native resolution is 800*RGB*1280. Features of this product are listed in the following table.

1.2 Functions & Features

Table1.1 Module Functions & Features

Parameter	Value	Unit
LCD Mode	a-Si TFT/transmissive	-
Color	16.7M	-
Display Resolution	800*3(RGB)*1280	pixels
Outline Dimension	99.85(H) *161.7(V) * 2.6 (T)	mm
Active Area(A.A)	94.20(H) * 150.72(V)	mm
Pixel pitch	0.03925(H) * 0.11775(V)	mm
Pixel Arrangement	RGB-stripe	-
Viewing Direction	Free	
Display Mode	Normally Black	
Drive IC	JD9366AB	-
Surface Treatment	Anti-Glare,Hardness:3H	
LCM Interface	LVDS_6Bit	

Pixel Arrangement

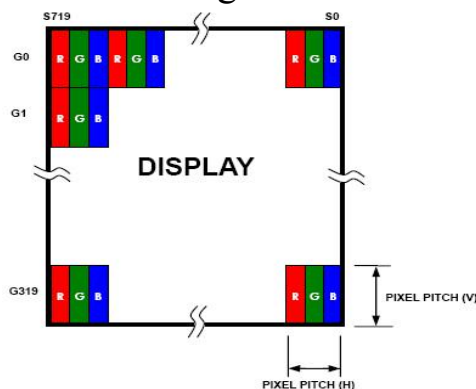

Messrs.			
Product Specification	Model:	TBF57003BFL20N	Rev. NO.
			A
			Issued Date.
			Mar,15.21

2. Mechanical Specification

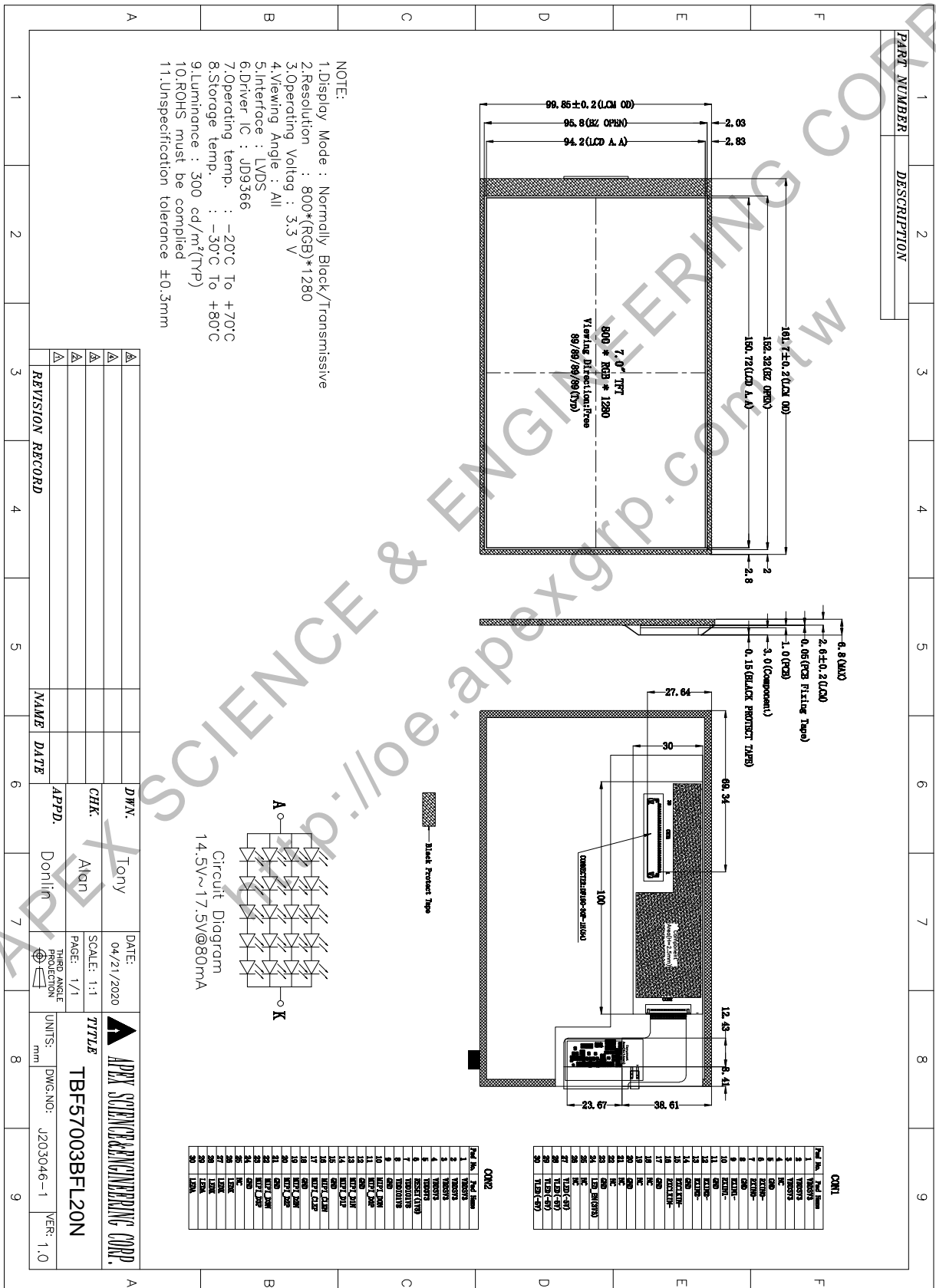

Messrs.				
Product Specification	Model:	TBF57003BFL20N	Rev. NO.	Issued Date.
			A	Mar,15.21

3. Pin Assignment

The electronics interface connector is DF19G-30P-1H(54). The connector interface pin assignments are listed in Table 6.

NO.	SYMBOL	Description
1	VDD	Power supply
2	VDD	Power supply
3	VDD	Power supply
4	NC	No connection
5	GND	Ground
6	RXINO-	-LVDS differential data input
7	RXINO+	+ LVDS differential data input
8	GND	Ground
9	RXIN1-	-LVDS differential data input
10	RXIN1+	+ LVDS differential data input
11	GND	Ground
12	RXIN2-	-LVDS differential data input
13	RXIN2+	+ LVDS differential data input
14	GND	Ground
15	RXCLKIN-	-LVDS differential clock input
16	RXCLKIN+	+ LVDS differential clock input
17	GND	Ground
18	NC	No connection
19	NC	No connection
20	GND	Ground
21	NC	No connection
22	NC	No connection
23	GND	Ground
24	LED_EN	Adjust for LED backlight brightness
25	NC	No connection
26	NC	No connection
27	VLED	Power supply for backlight Circuit(5V)
28	VLED	Power supply for backlight Circuit(5V)
29	VLED	Power supply for backlight Circuit(5V)
30	VLED	Power supply for backlight Circuit(5V)

Messrs.				
Product Specification	Model:	TBF57003BFL20N	Rev. NO.	Issued Date.
			A	Mar,15.21

4.ELECTRICAL CHARACTERISTICS

4.1 Electrical Specification

<Table 4.1. Electrical specifications>

Item	Symbol	Unit	Value			Note
			Min	Typ	Max	
Power voltage	VDD	V	3.0	3.3	3.6	
	VLED	V	3.3	5.0	6.5	
Operating Temperature	TOP	°C	-20 to		+70	
Storage Temperature	TST	°C	-30 to		+80	

4.2 Recommended Driving Condition for Backlight

Table 4.2 Back-light Specification

Item	Symbol	Min.	Typ.	Max.	Unit	Note
Supply Voltage	VF	14.5	15.5	16.5	V	
Supply Current	IF	68	80	90	mA	
Uniformity	B	80	-	-	(%)	
Backlight Power Consumption	P	986	1240	1575	mW	
Backlight lifetime	T	30000			hrs	
Power supply for led	VLED	4.5	5.0	5.5	V	
Fpwm	Dimming Frequency	1K	-	100K	Hz	PWM Dimming
Dimming	Swing Voltage	0		3.3	Volt	
Dimming Duty cycle		3	--	100	(%)	

Messrs.			
Product Specification	Model:	TBF57003BFL20N	Rev. NO.
			Issued Date.
			A
			Mar,15.21

5.0 Electrical Specification

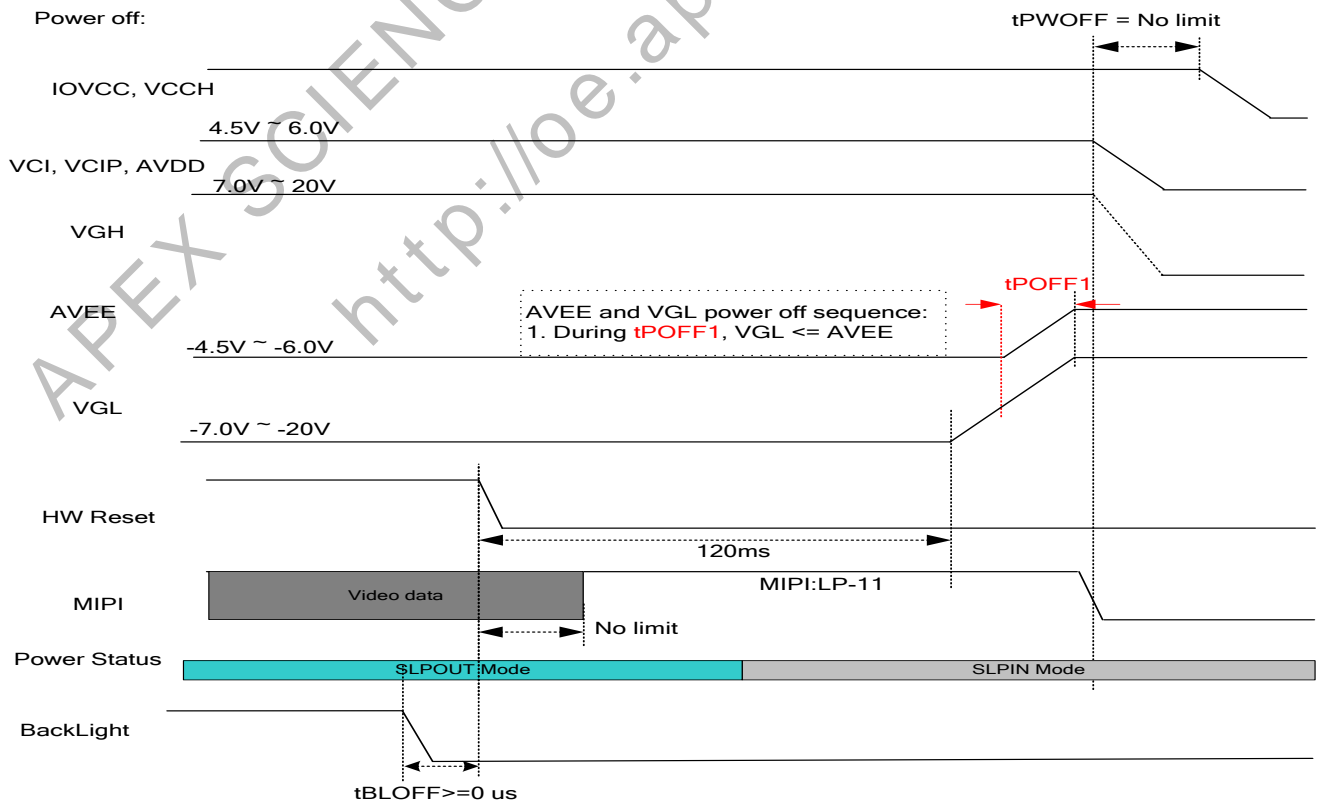
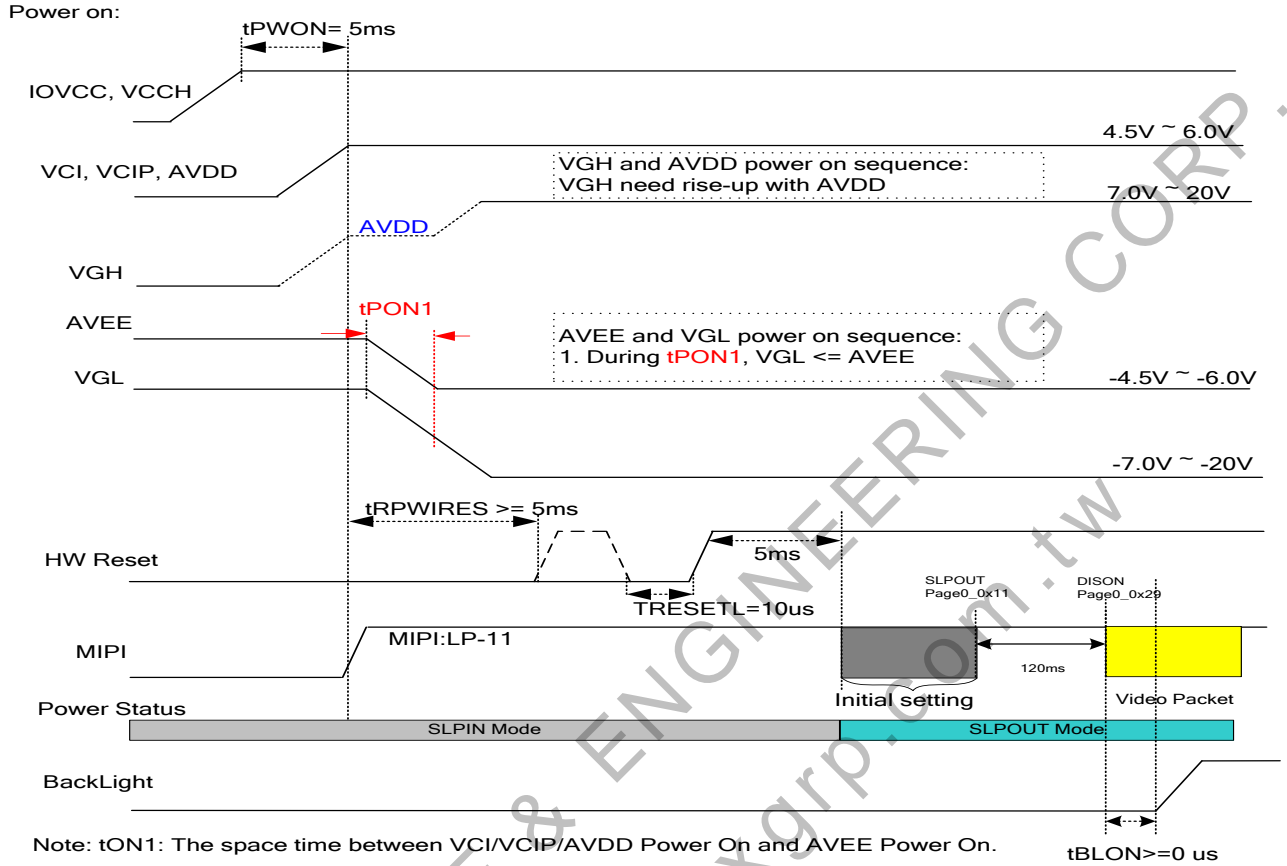

Messrs.				
Product Specification	Model:	TBF57003BFL20N	Rev. NO.	Issued Date.
			A	Mar,15.21

Resolution		800RGBx1280			Unit	Note
Input Timing	Symbol	Min.	Typ.	Max.		
PCLK Frequency	-		71.9		MHz	
Horizontal Total	THT	11	120	88	DCLK	
Horizontal Synchronization	THS	6	24	-	DCLK	
Horizontal Back Porch	THB	5	24	-	DCLK	
Horizontal Address	THA	-	800	-	DCLK	
Horizontal Front Porch	THF	5	72		DCLK	
Vertical Frequency	-	-	60	-	Hz	
Vertical Total	TVT	6	24	-	THT	
Vertical Synchronization	TVS	2	2	-	THT	
Vertical Back Porch	TVB	2	10	-	THT	
Vertical Address	TVA	-	1280	-	THT	
Vertical Front Porch	TVF	2	12	-	THT	

Messrs.				
Product Specification	Model:	TBF57003BFL20N	Rev. NO.	Issued Date.
			A	Mar,15.21

6 Optical Specifications

Item	Symbol	Condition	Min.	Typ.	Max.	Unit	Note
Transmittance (With PZ)	T		4.0	4.75	—	%	
Contrast	CR		700	900	1100		(1)(2)
Response time (Rising+Falling)	TRT			30	50	msec	(1)(3)
White luminance(center)	YL		250	300	-	cd/m ²	I=80mA
Color gamut	S		45	50		%	C light
Color chromaticity (CIE1931)	White	W _x	⊖ =0 Normal viewing angle	-0.03	+0.03		(1)(4) CF Glass C light
		W _y					
	Red	R _x					
		R _y					
	Green	G _x					
		G _y					
	Blue	B _x					
		B _y					
Viewing angle	Hor.	⊖ L	80	89	—		
		⊖ R	80	89	—		
	Ver.	⊖ U	80	89			
		⊖ D	80	89			
Optima View Direction	Free						(5)

Note (1) Definition of Viewing Angle:

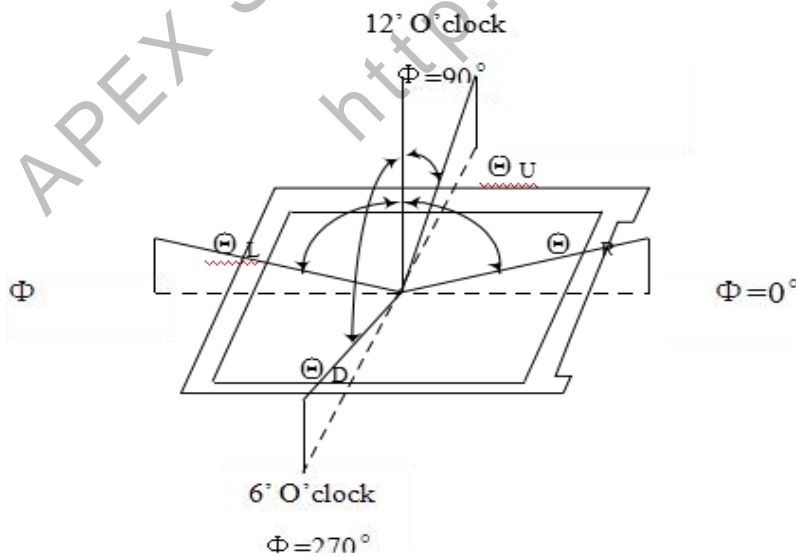

Messrs.			
Product Specification	Model:	TBF57003BFL20N	Rev. NO.
			Issued Date.
			A
			Mar,15.21

Note (2) Definition of Contrast Ratio (CR): measured at the center point of pane

$$CR = \frac{\text{Luminance with all pixels white}}{\text{Luminance with all pixels black}}$$

Note (3) Definition of Response Time: Sum of T_R and T_F

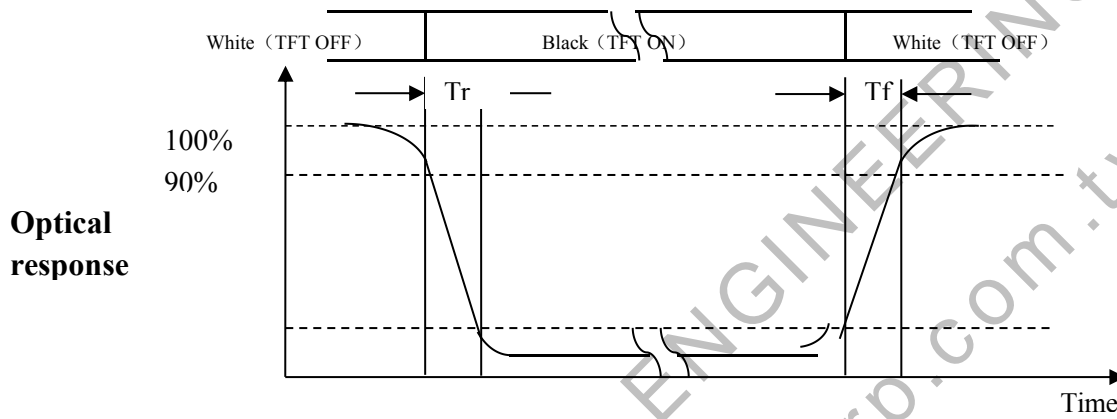

Note (4) Definition of optical measurement setup

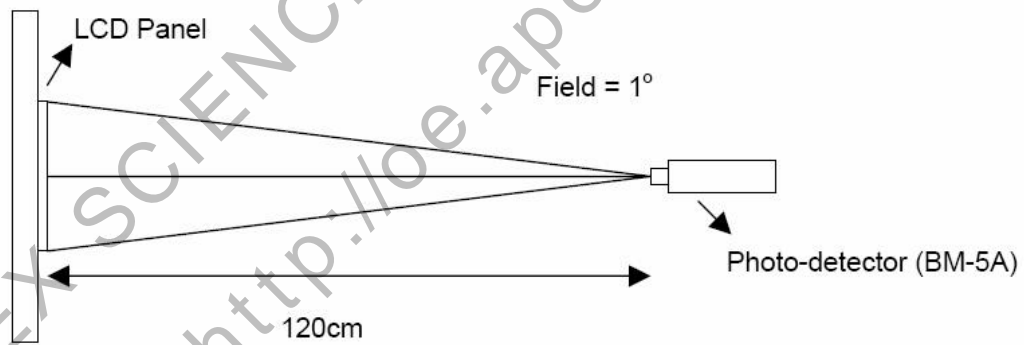

Note (5) Rubbing Direction (The different Rubbing Direction will cause the different optimal view direction).

Messrs.			
Product Specification	Model:	TBF57003BFL20N	Rev. NO.
			Issued Date.
			A Mar,15.21

7. Reliability Test Items

No.	Item	Conditions	Remark
1	High Temperature Storage	Ta=+80oC, 240hrs	
2	Low Temperature Storage	Ta=-30oC, 240hrs	
3	High Temperature Operation	Ta=+70oC, 240hrs	
4	Low Temperature Operation	Ta=-20oC, 240hrs	
5	High Temperature and High Humidity (operation)	Ta=+50oC, 90%RH, 120hrs	
6	Thermal Cycling Test (non operation)	-20oC(30min) → +70oC(30min), 100cycles	
7	Life time	50,000 hours 25oC,60%RH Specification condition driving	
8	Electrostatic Discharge	Contact: 150pF,330 Ω , ±8KV, class B Air: 150pF,330 Ω , ±4KV, class B	
9	Vibration	1. Random: 1.04Grms, 5~500Hz, X/Y/Z, 30min/each direction 2. Sine: Freq. Range: 8~33.3Hz Stoke: 1.3mm Sweep: 2.9G, 33.3~400Hz X/Z: 2hr, Y: 4hr, cyc: 15min	
10	Shock	100G, 6ms, ±X, ±Y, ±Z 3 time for each direction	JIS C7021, A-10 (Condition A)
11	Vibration (with carton)	Random: 0.015G ² /Hz, 5~200Hz -6dB/Octave, 200~400Hz XYZ each direction: 2hr	
12	Drop (with carton)	Height: 60cm 1 corner, 3 edges, 6 surfaces	JIS Z0202
13	Image sticking test	A. Turn to 5X5 black/white check-board pattern and lighting-on aging 4 hour. B. Change to 50% graylevel(gray level 128) pattern and stabilize with 5 minutes. C. The image sticking can't see with ND6% filter	

Note: There is no display function NG issue occurred, all the cosmetic specification is judged before the reliability stress.

Messrs.			
Product Specification	Model:	TBF57003BFL20N	Rev. NO.
			A
			Issued Date.
			Mar,15.21

8. Handling Precautions

8.1 Safety

The liquid crystal in the LCD is poisonous. Keep away from your mouth and eyes. If the liquid crystal contacts with your skin, mouse or clothes, use soap to wash it off immediately.

8.2 Handling

- i. The LCD panel is made by thin glass. Prevent the panel from mechanical shock or putting excessive force on its surface.
- ii. The polarizer attached on the display is very easy to be damaged, handle it with special attention.
- iii. To avoid contamination on the display surface, do not touch the display surface with bare hands.
- iv. The transparent electrodes may be disconnected if you use the LCD panel under dew-condensing environment.
- v. The characteristics of the semiconductor devices may be affected when they are exposed to light, possibly resulting in malfunctioning of the ICs. To prevent such malfunctioning of the ICs, make sure the application and the mounting of the panel are designed so that the IC is not exposed to light.

8.3 Static Electricity

Ground soldering iron tips, tools and testers when you operate. Also ground your body when handling the products and store the products in an anti-electrostatic container.

8.4 Storage

Store the products in a dark place where the temperature is within the range of 25 ± 10 and with low humidity (65%RH or less). Do not store the LCD product in an atmosphere containing organic solvents or corrosive gases.

8.5 Cleaning

Do not wipe the polarizer with dry cloth, as it might cause scratching. Wipe the polarizer with a soft cloth soaked with petroleum IPA. Other chemical might damage the panel.

Messrs.			
Product Specification	Model:	TBF57003BFL20N	Rev. NO.
			A
			Issued Date.
			Mar,15.21

9 . INSPECTION CRITERION

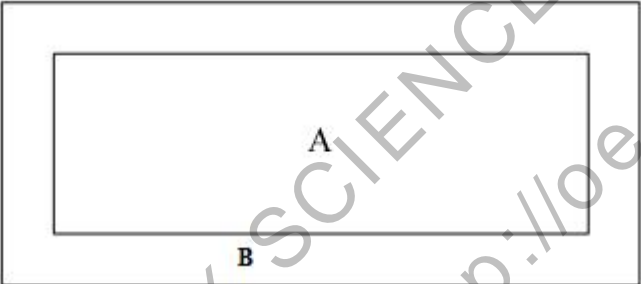
TITLE:FUNCTIONAL TEST & INSPECTION CRITERIA	LCM Product
<p>This specification is made to be used as the standard acceptance/rejection criteria for Color mobile phone LCM with touch panel.</p> <p>1 Sample plan</p> <p>Sampling plan according to GB/T2828.1-2003/ISO 2859-1: 1999, normal level 2 and based on:</p> <p>Major defect: AQL 0.65</p> <p>Minor defect: AQL 1.5</p> <p>2 Inspection condition</p> <p>Viewing distance for cosmetic inspection is about 30 cm with bare eyes, and under an environment of 20~40W light intensity, all directions for inspecting the sample should be within 45° against perpendicular line.</p> <p>3 Definition of inspection zone in LCD</p>  <p>Zone A: character/Digit area</p> <p>Zone B: viewing area except Zone A (Zone A + Zone B=minimum Viewing area)</p> <p>Zone C: Outside viewing area (invisible area after assembly in customer's product)</p> <p>Fig.1 Inspection zones in an LCD.</p> <p>Note: As a general rule, visual defects in Zone C are permissible, when it is no trouble for quality and assembly of customer's product.</p>	
TITLE:FUNCTIONAL TEST & INSPECTION CRITERIA	LCM Product

Messrs.			
Product Specification	Model:	TBF57003BFL20N	Rev. NO.
			A
			Issued Date.
			Mar,15.21

4 Inspection standards

4.1 Major Defect

Item NO.	Items to be Classification	Inspection Standard	Classification of defects
4.1.1	All functional defects	1) No display 2) Display abnormally 3) Missing vertical, horizontal segment defects 4) Short circuit 5) Back-light no lighting, flickering and abnormal lighting.	Major
4.1.2	Missing	Component Missing	
4.1.3	Outline dimension	Overall outline dimension beyond the drawing is not allowed.	
4.1.4	linearity	No more than 1.5%	

4.2 Cosmetic Defect

4.2.1 Spots defect

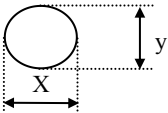
Item NO	Items to be Classification	Inspection Standard	Classification of defects												
4.2.1	Clear Spots Black and White dot,scratch, Contamination	For dark/white spot, size Φ is define as:  $\Phi = (X+Y) / 2$	Minor												
		<p>1.</p> <table border="1"> <thead> <tr> <th rowspan="2">Zone Size (mm)</th> <th colspan="2">Acceptable Qty</th> </tr> <tr> <th>A</th> <th>B</th> </tr> </thead> <tbody> <tr> <td>$\Phi \leq 0.2$</td> <td>Ignore</td> <td rowspan="3">Ignore</td> </tr> <tr> <td>$0.2 < \Phi \leq 0.40$</td> <td>3</td> </tr> <tr> <td>$0.40 < \Phi$</td> <td>0</td> </tr> <tr> <td>Total</td> <td>3</td> <td></td> </tr> </tbody> </table>		Zone Size (mm)	Acceptable Qty		A	B	$\Phi \leq 0.2$	Ignore	Ignore	$0.2 < \Phi \leq 0.40$	3	$0.40 < \Phi$	0
Zone Size (mm)	Acceptable Qty														
	A	B													
$\Phi \leq 0.2$	Ignore	Ignore													
$0.2 < \Phi \leq 0.40$	3														
$0.40 < \Phi$	0														
Total	3														

TITLE:FUNCTIONAL TEST & INSPECTION CRITERIA

LCM Product

4.2.2 Line defect

Messrs.			
Product Specification	Model:	TBF57003BFL20N	Rev. NO.
			A
			Issued Date.
			Mar,15.21

Item NO	Items to be Classification	Inspection Standard				Classification of defects
4.2.2	Line type	size(mm)		Acceptable Qty		Minor
		L(Length)	W(Width)	zone		
				A	B	
		Ignore	$W \leq 0.03$	Ignore		
		$L \leq 10.0$	$0.03 < W \leq 0.05$	4		
		$L \leq 5.0$	$0.05 < W \leq 0.10$	2		
			$0.1 < W$	Define as spot defect		
Total		6				

TITLE:FUNCTIONAL TEST & INSPECTION CRITERIA



LCM Product

4.2.4	Polarize Air bubble	Zone		Acceptable Qty		Minor	
		Size (mm)			A		B
			$\Phi \leq 0.25$	Ignore			Ignore
		$0.25 < \Phi \leq 0.50$	3				
		$0.50 < \Phi$	0				
Total		3					

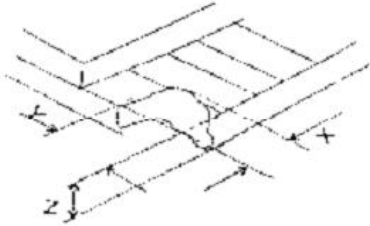
4.2.3 LCD chip defect

Item NO	Items to be Classification	Inspection Standard			Classification of defects
4.2.5	Glass defect	Notes: X:The length of crack, Y:The width of crack, Z:The thickness of crack, S:contact pad length ,			Minor
		(i) Chips on corner			
		A:LCD Glass defect			
					
		X (mm)	Y (mm)	Z (mm)	
		≤ 2.0	$\leq S$	Disregard	
Chips on the corner of terminal shall not be allowed to extend into the ITO pad or expose perimeter seal.					

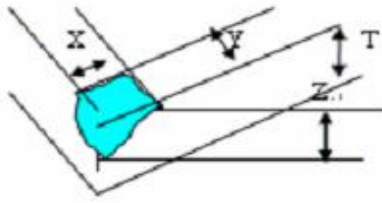
Messrs.			
Product Specification	Model:	TBF57003BFL20N	Rev. NO.
			A
			Issued Date. Mar,15.21

		 <table border="1" data-bbox="534 504 1220 593"> <tr> <td>X (mm)</td> <td>Y (mm)</td> <td>Z (mm)</td> </tr> <tr> <td>≤3.0</td> <td>≤3.0</td> <td>Disregard</td> </tr> </table> <p>(ii) Usual surface cracks A: LCD Glass defect</p> 	X (mm)	Y (mm)	Z (mm)	≤3.0	≤3.0	Disregard	
X (mm)	Y (mm)	Z (mm)							
≤3.0	≤3.0	Disregard							

TITLE: FUNCTIONAL TEST & INSPECTION CRITERIA

LCM Product

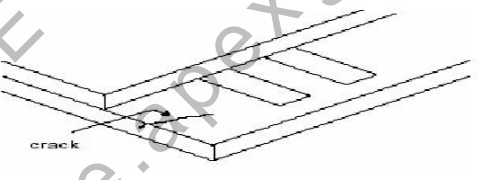
		<p>(iii) Crack Cracks tend to break are not allowed.</p> 	Major
--	--	---	--------------

4.3 Parts Defect

Item NO	Items to be Classification	Inspection Standard	Classification of defects
4.3.1	Parts contra position	1、 Not allow IC and FPC/heat-seal lead width is more than 50% beyond lead pattern. 2、 Not allow chip or solder component is off center more than 50% of the pad outline.	Major
4.3.2	SMT	According to the <Acceptability of electronic assemblies> IPC-A-610C class 2 standard. Component missing or function defect are Major defect, the others are Minor defect.	

Messrs.			
Product Specification	Model:	TBF57003BFL20N	Rev. NO.
			Issued Date.
			A
			Mar,15.21

10 . PACKAGE SPECIFICATION

1. 包装

- 1). 将1片模组装入1个专用的静电袋内.
- 2). 将垫好珍珠棉的1片产品装入泡棉箱卡槽内

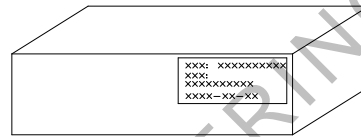
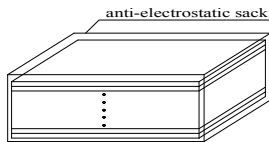

- 4). 将泡棉箱放入大纸箱内.
2. 其它:如我司或客户两方任何一方对承认书的内容有问题或疑议,须在双方都同意的情况下共同寻求解决的方案.
3. 包装示意图



一个产品

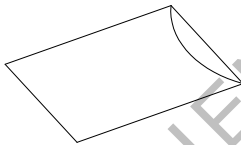

一个静电袋装1PCS产品.
PE袋尺寸: 200*120mm

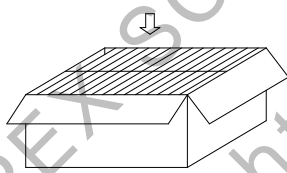

一个大箱装内装1个泡棉盒, 1个泡棉盒
可以装24个静电袋
一大箱=24PCS产品
一个大箱尺寸:445*354*163mm

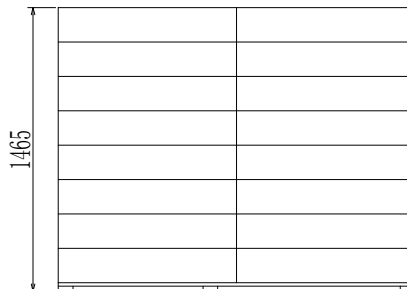
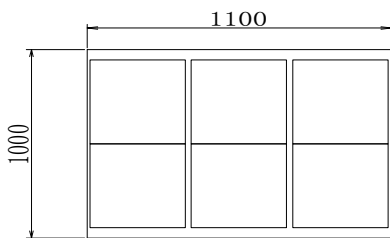

一个卡板每层装6箱
一个卡板装8层=8*6=48箱
一个卡板=48*24=1152PCS产品
一板货的外形尺寸1100*1000*1465MM